

Specifications

MODEL	GTH™-5022 R	
MEASUREMENTS	Metric	Imperial
Lifting height maximum	21.93 m	71 ft 11 in
Lifting capacity maximum	5,000 kg	11,022 lbs
Lift capacity at maximum height	2,500 kg	5,511 lbs
Lift capacity at maximum reach	400 kg	882 lbs
Forward reach maximum	18.93 m	62 ft 1 in
Reach at maximum height	4.10 m	13 ft 5 in
A Height	3.05 m	10 ft
B Height at steering wheel	2.20 m	7 ft 3 in
C Width	2.49 m	8 ft 2 in
D Cab width	93 cm	3 ft
E Track	2.02 m	6 ft 8 in
F Wheelbase	3.50 m	11 ft 6 in
G Length at stabilisers	6.06 m	19 ft 11 in
H Length at fork-holder plate	7.70 m	25 ft 3 in
I Ground clearance	43 cm	1 ft 5 in
L Overall width, stabilisers extended	5.15 m	16 ft 11 in
M Side rear overhang	2.87 m	9 ft 5 in
N Side front overhang	4.67 m	15 ft 4 in
O Overall length	8.88 m	29 ft 2 in
P Overall front overhang	5.85 m	19 ft 2 in
O1 Obstruction angle	17°	17°
O2 Departure angle	17°	17°

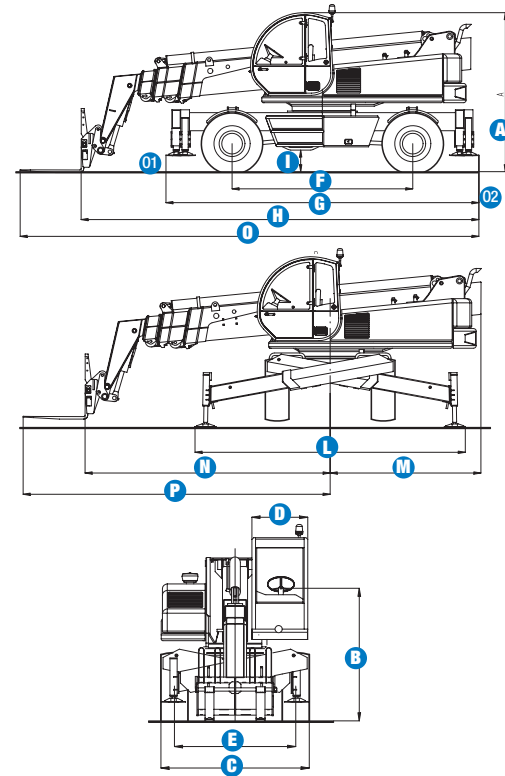

PRODUCTIVITY		
Inside/outside turning radius	2.55 m/4.82 m	8 ft 4 in/15 ft 10 in
Break out force (with 500L shovel SAE J 732)	8,400 kg	18,518 lbs
Towing capacity at dynamometer**	11,500 kg/11,500 kg	25,353 lbs/25,353 lbs
Drive speed max.	30 km/h	18.6 mph
Fork-holder plate rotation	131°	131°
Chassis levelling on front axle	+/- 8°	+/- 8°
Floating forks	L 1200 mm Section 150x50 mm	L 3 ft 11 in Section 6 in x 2 in
Tyres (DIN 70361)	445/65 R 22.5" AR-01	
Lifting/lowering speed**	25 sec./18 sec.	25 sec./18 sec.
Extension/retraction speed**	38 sec./21 sec.	38 sec./21 sec.

POWER		
Engine	Perkins 1106D-E66TA 6-cylinder T Diesel 156 hp (116.5 kW), Tier 3	
Tank capacities	Fuel	125 L / 27.5 gal
	Engine oil	18 L / 4 gal
	Hydraulic oil	200 L / 44 gal

SOUND LEVEL		
Sound pressure level (operator position)	76 dB (LpA)	76 dB (LpA)
Guaranteed sound power level	105 dB (LwA)	105 dB (LwA)

VIBRATION LEVEL		
Vibration level hand-arm system	<2.5 m/s ²	<8 ft 2 in/s ²
Vibration level whole body	0.23 m/s ²	9 in/s ²

WEIGHT		
Weight***	19,250 kg	42,435 lbs

STANDARDS COMPLIANCE		
EU Machinery Directive 2006/42/EC		
Operating cab conforms to ISO3471 (ROPS) and ISO3449 (FOPS)		
Low emission engine conforms to EU Directive 97/68/EC stage III		
2000/14/EC EU Directive (noise)		

*Max. load, **Without load
*** Weight will vary depending on options and/or country standards

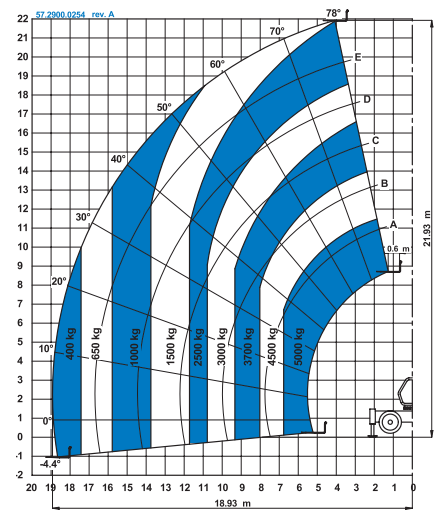

Lift capacity chart (with stabilisers, 0°)

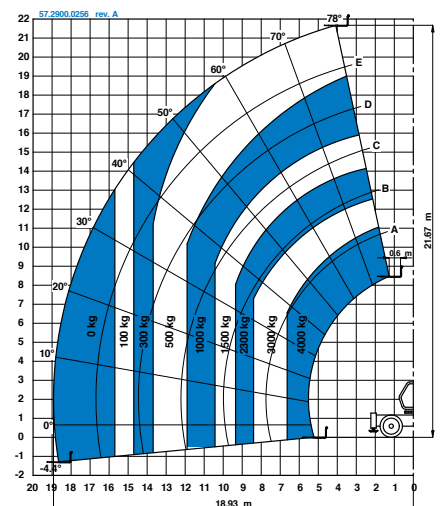

Lift capacity chart (without stabilisers, 0°)

Features

STANDARD FEATURES

MEASUREMENTS

- 5,000 kg (11,022 lb) maximum lift capacity
- 21.93 m (71 ft 11 in) maximum lift height
- 18.93 m (62 ft 1 in) maximum forward reach

PRODUCTIVITY

- 4 x 4
- 4 - wheel drive
- 3 steering modes:
 - front wheel steer
 - crab steer
 - coordinated steer
- Hydraulic line on boom
- Electric line on boom including cable reel and cable bracket
- Power assisted steering
- Front and rear stabilisers
- Continuous rotation
- Hydrostatic transmission with variable displacement pump and motor
- Two-speed mechanical gearbox with electric two-mode switch
- Multifunction electro-proportional 5x1 joystick
- Limited slip differential on front axle
- Chassis leveling on front axle +/- 8°
- Floating forks
- Attachment holder plate with hydraulic coupling
- Two-section door (glass upper/steel lower)
- Electronic angle/length indicators (monitor)
- Battery disconnection switch
- Adjustable suspended seat with operator detection seat switch
- Large diameter steering wheel
- Front & rear windscreen wipers
- Sunshield
- Roof protection grid
- Two side rear view mirrors
- Front & rear lights
- Side mounted engine for easy access to components
- Oil immersed, multi-disc brakes on both axles
- Lockable fuel tank
- Longitudinal stability control system :
 - Visible display and load moment LEDs indicator
 - Audible alarm
 - Automatic lock-out of boom extension and lowering
 - Automatic lock-out of stabilisers
 - Automatic lock-out of rear axle
- Maintenance collar
- Man-platform/Jib/Winch pre-arrangement

POWER

- Perkins Turbo Diesel 156 hp (116.5 kW)

TYRES

- 445/65 R 22.5" AR-01-TL (DIN 70361)

OPTIONS & ACCESSORIES

PRODUCTIVITY

- Air conditioning
- Second hydraulic line on boom
- Concrete mixing bucket pre-arrangement
- Centering holder boom pre-arrangement
- Windshield protection grid
- Adjustable spotlight on boom
- Adjustable spotlight on cab
- Fish eye rear view mirror in the back
- Wiper on cab roof
- Water muffler
- Second joystick kit on left handside
- Radio remote control
- High proportional valve-block
- Optical-audible system for stabilisers
- Foam filled tyre 445/66 R22.5 AR-01-TL
- Biodegradable naturelle HF-E Shell oil
- 6-ton towing hitch

ATTACHMENT OPTIONS

- Spare wheel 445/66 R22.5
- Spare wheel foam filled 445/66 R22.5
- Loading shovel 500 L
- Concrete bucket 500/800 L manual/hydraulic discharge
- Concrete mixing bucket 500 L with remote control
- Brick-holder basket
- Hydraulic jack 20 ton and 30 mm wheel nut wrench
- FEM 3 plate and forks kit
- Fork side-shift (+/- 100 mm)
- Fixed hook on plate
- 4 m jib, 900 kg capacity
- 4 m jib with 900 kg capacity hydraulic winch
- Hydraulic winch 3000/5000 kg
- Centering holder boom
- Fixed man-platform
- Rotating / Extendable man-platform



CO.MA.CO S.r.l.

via XIV Strada 21 - 20020 Cesate (MI) - Italy

Tel. +39 02 99065169

info@comacopro.com

www.comacopro.com