



DIECI



37.7



37.8



38.10



33.11

ZEUS

PERFORMANCE				
Machine model	ZEUS 37.7	ZEUS 37.8	ZEUS 38.10	ZEUS 33.11
Maximum capacity	3700 kg (8157 lb)	3700 kg (8157 lb)	3800 kg (8378 lb)	3300 kg (7275 lb)
Maximum lifting height on wheels	7,35 m (24 ft)	7,80 m (26 ft)	9,75 m (32 ft)	10,60 m (35 ft)
Maximum horizontal extension on wheels	4,00 m (13 ft)	4,45 m (15 ft)	6,45 m (21 ft)	7,35 m (24 ft)
Fork swiveling angle	146°	146°	146°	146°
Pull-out force	5700 daN (12814 lbf)	5700 daN (12814 lbf)	5700 daN (12814 lbf)	5700 daN (12814 lbf)
Towing force	7300 daN (16411 lbf)	7300 daN (16411 lbf)	7300 daN (16411 lbf)	7300 daN (16411 lbf)
Maximum climb angle	40%	40%	40%	40%
Unladen weight	7600 kg (16755 lb)	7700 kg (16976 lb)	8000 kg (17637 lb)	8200 kg (18078 lb)
Maximum speed	40 km/h (24,9 mph)	40 km/h (24,9 mph)	40 km/h (24,9 mph)	40 km/h (24,9 mph)
BOOM				
Machine model	ZEUS 37.7	ZEUS 37.8	ZEUS 38.10	ZEUS 33.11
Lifting	7,3 s	7,2 s	8,7 s	8,7 s
Getting off the basket	3,8 s	3,7 s	5,0 s	5,0 s
Extension	5,2 s	5,5 s	7,6 s	8,6 s
Retraction	2,9 s	3,1 s	4,6 s	5,2 s
Forward swiveling	2,7 s	2,7 s	2,7 s	2,7 s
Reverse swiveling	1,7 s	1,6 s	1,6 s	1,6 s
ENGINE				
Machine model	ZEUS 37.7	ZEUS 37.8	ZEUS 38.10	ZEUS 33.11
Brand	Kubota	Kubota	Kubota	Kubota
Nominal power	83,5 kW (112 HP)	83,5 kW (112 HP)	83,5 kW (112 HP)	83,5 kW (112 HP)
@rpm	2600 rpm	2600 rpm	2600 rpm	2600 rpm
Operation	4-stroke	4-stroke	4-stroke	4-stroke
Injection	Electronic, Common Rail	Electronic, Common Rail	Electronic, Common Rail	Electronic, Common Rail
Number and arrangement of cylinders	4, Vertical in line	4, Vertical in line	4, Vertical in line	4, Vertical in line
Displacement	3769 cm ³ (230 in ³)	3769 cm ³ (230 in ³)	3769 cm ³ (230 in ³)	3769 cm ³ (230 in ³)
Consumption	231 g/kWh (380 lb/Hp h)	231 g/kWh (380 lb/Hp h)	231 g/kWh (380 lb/Hp h)	231 g/kWh (380 lb/Hp h)
@rpm	2600 rpm	2600 rpm	2600 rpm	2600 rpm
Emission standards	Stage IIIB/Tier 4i	Stage IIIB/Tier 4i	Stage IIIB/Tier 4i	Stage IIIB/Tier 4i
Exhaust gas treatment	Particulate filter (DPF)	Particulate filter (DPF)	Particulate filter (DPF)	Particulate filter (DPF)
Cooling system	Liquid	Liquid	Liquid	Liquid
Intake	Turbo compressor after-cooler	Turbo compressor after-cooler	Turbo compressor after-cooler	Turbo compressor after-cooler
DIFFERENTIAL AXLES				
Machine model	ZEUS 37.7	ZEUS 37.8	ZEUS 38.10	ZEUS 33.11
Axles type	2 steering, with 4 planetary reduction gears	2 steering, with 4 planetary reduction gears	2 steering, with 4 planetary reduction gears	2 steering, with 4 planetary reduction gears
Type of steering	4 wheels / transversal / 2 wheels	4 wheels / transversal / 2 wheels	4 wheels / transversal / 2 wheels	4 wheels / transversal / 2 wheels
Front axle	Rigid	Rigid	Rigid	Rigid
Rear axle	Swinging	Swinging	Swinging	Swinging
Service braking	Oil bath with servo brake on front axle	Oil bath with servo brake on front axle	Oil bath with servo brake on front axle	Oil bath with servo brake on front axle
Parking braking	Negative actuation with electrical control	Negative actuation with electrical control	Negative actuation with electrical control	Negative actuation with electrical control
HYDRAULIC SYSTEM				
Machine model	ZEUS 37.7	ZEUS 37.8	ZEUS 38.10	ZEUS 33.11
Hydraulic pump type	Gear pump for power steering and movements	Gear pump for power steering and movements	Gear pump for power steering and movements	Gear pump for power steering and movements
Hydraulic pump capacity	170 L/min (44,9 gal/min)	170 L/min (44,9 gal/min)	170 L/min (44,9 gal/min)	170 L/min (44,9 gal/min)
Max. operating pressure	25,0 MPa (3626 psi)	25,0 MPa (3626 psi)	25,0 MPa (3626 psi)	25,0 MPa (3626 psi)
Distributor control	4in1 proportional Joystick	4in1 proportional Joystick	4in1 proportional Joystick	4in1 proportional Joystick
REFUELING				
Machine model	ZEUS 37.7	ZEUS 37.8	ZEUS 38.10	ZEUS 33.11
Hydraulic system (total)	140,0 L (36,98 gal)	140,0 L (36,98 gal)	140,0 L (36,98 gal)	140,0 L (36,98 gal)
Diesel tank	100,0 L (26,42 gal)	100,0 L (26,42 gal)	100,0 L (26,42 gal)	100,0 L (26,42 gal)
TRANSMISSION				
Machine model	ZEUS 37.7	ZEUS 37.8	ZEUS 38.10	ZEUS 33.11
Transmission type	Hydrostatic with variable flow pump	Hydrostatic with variable flow pump	Hydrostatic with variable flow pump	Hydrostatic with variable flow pump
Hydraulic motor	Hydrostatic with continuous automatic adjustment	Hydrostatic with continuous automatic adjustment	Hydrostatic with continuous automatic adjustment	Hydrostatic with continuous automatic adjustment
Reversal	Electro-Hydraulic	Electro-Hydraulic	Electro-Hydraulic	Electro-Hydraulic
Inching	With hydraulic pedal for controlled forward movement	With hydraulic pedal for controlled forward movement	With hydraulic pedal for controlled forward movement	With hydraulic pedal for controlled forward movement
Transmission gearbox	Servocontrolled 2-speed	Servocontrolled 2-speed	Servocontrolled 2-speed	Servocontrolled 2-speed

TIRES

Machine model	ZEUS 37.7	ZEUS 37.8	ZEUS 38.10	ZEUS 33.11
Standard tires	400/70x20"	400/70x20"	400/70x20"	400/70x20"
Optional tires	400/70x24"; 18x22.5"	400/70x24"; 18x22.5"	400/70x24"; 18x22.5"	400/70x24"; 18x22.5"

DIMENSIONS

Machine model	ZEUS 37.7	ZEUS 37.8	ZEUS 38.10	ZEUS 33.11
A	340 mm (13,4 in)	340 mm (13,4 in)	340 mm (13,4 in)	340 mm (13,4 in)
B	1380 mm (54,3 in)	1620 mm (63,8 in)	1380 mm (54,3 in)	1730 mm (68,1 in)
C	2600 mm (102,4 in)	2600 mm (102,4 in)	2600 mm (102,4 in)	2600 mm (102,4 in)
D	970 mm (38,2 in)	970 mm (38,2 in)	970 mm (38,2 in)	970 mm (38,2 in)
F	4060 mm (159,8 in)	4060 mm (159,8 in)	4060 mm (159,8 in)	4060 mm (159,8 in)
G	4950 mm (194,9 in)	4950 mm (194,9 in)	4950 mm (194,9 in)	5300 mm (208,7 in)
H	2310 mm (90,9 in)	2310 mm (90,9 in)	2310 mm (90,9 in)	2310 mm (90,9 in)
I	940 mm (37 in)	940 mm (37 in)	940 mm (37 in)	940 mm (37 in)
L	1780 mm (70,1 in)	1780 mm (70,1 in)	1780 mm (70,1 in)	1780 mm (70,1 in)
M	2290 mm (90,2 in)	2290 mm (90,2 in)	2290 mm (90,2 in)	2290 mm (90,2 in)
O	3700 mm (145,7 in)	4050 mm (159,4 in)	3700 mm (145,7 in)	5150 mm (202,8 in)
P	950 mm (37,4 in)	950 mm (37,4 in)	950 mm (37,4 in)	950 mm (37,4 in)
Q	3450 mm (135,8 in)	3450 mm (135,8 in)	3450 mm (135,8 in)	3450 mm (135,8 in)
T	175 mm (6,9 in)	160 mm (6,3 in)	220 mm (8,7 in)	183 mm (7,2 in)

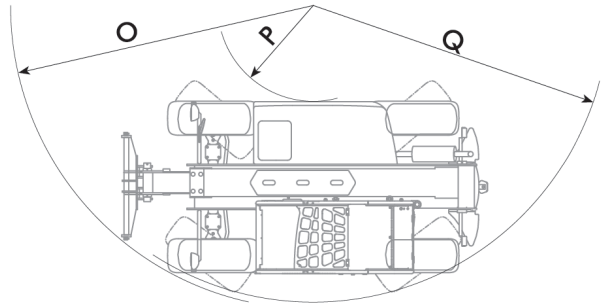
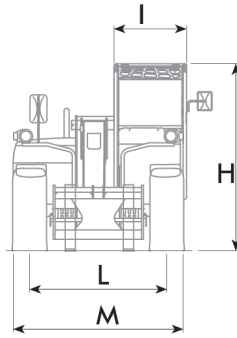
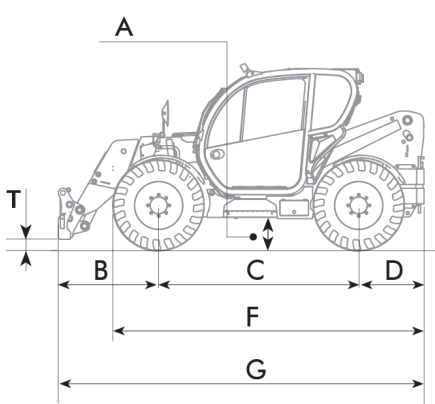

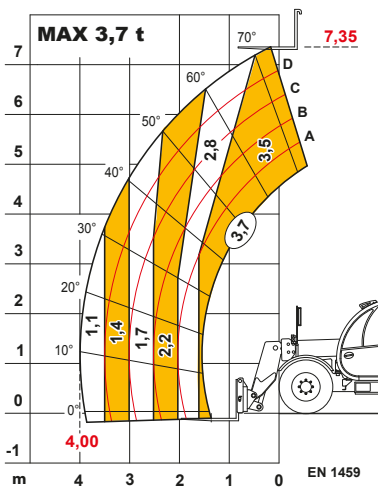

Zeus 37.7

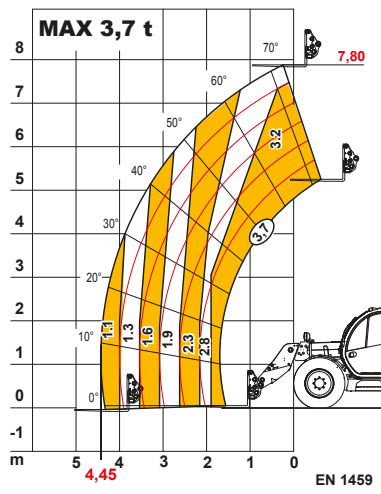

Zeus 37.8

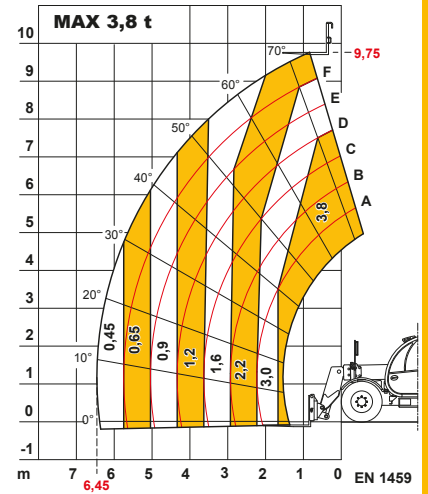

Zeus 38.10

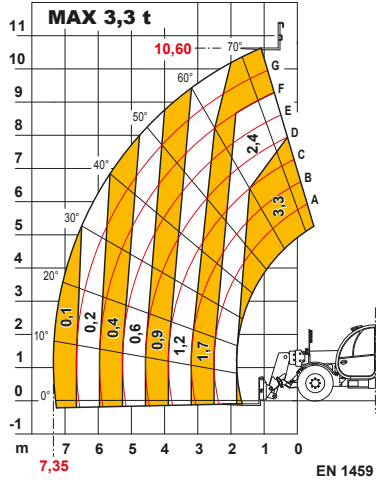

Zeus 33.11

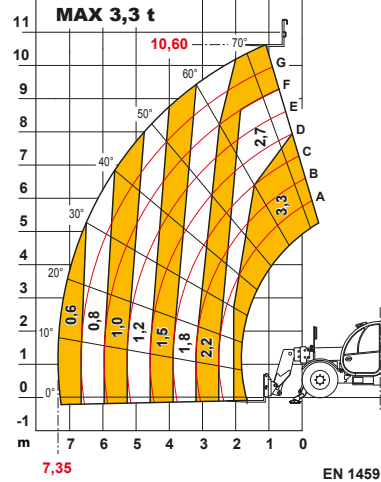

Zeus 33.11



CO.MA.CO S.r.l.
 via XIV Strada 21 - 20020 Cesate (MI) - Italy
 Tel. +39 02 99065169
 info@comacopro.com
 www.comacopro.com