

Material Lifts

Super Tower™

Specifications

Models	ST-20	US	ST-25	US
Measurements	Metric	US	Metric	US
A Height - stowed	2.2 m	6 ft 6.75 in	2.2 m	6 ft 6.75 in
B Length - stowed	64 cm	2 ft 1.25 in	64 cm	2 ft 1.25 in
C Width - stowed	56 cm	1 ft 10 in	56 cm	1 ft 10 in
D Load height minimum	15 cm	6 in	15 cm	6 in
E Ground clearance - center	5 cm	2 in	5 cm	2 in
Working height - forks up	6.46 m	21 ft 2.5 in	7.94 m	26 ft 0.5 in
- forks down	5.94 m	19 ft 6 in	7.42 m	24 ft 4 in

Productivity

Load capacity - at 46 cm (18 in) load center	363 kg	800 lbs	295 kg	650 lbs
Length - adjustable forks	70 cm	27.5 in	70 cm	27.5 in
Width - adjustable forks	29–76 cm	11.5–30 in	29–76 cm	11.5–30 in
Fork extensions detached each (l/w/d)	76/5/8 cm; 2 kg	30/2/3 in; 4.5 lbs	76/5/8 cm; 2 kg	30/2/3 in; 4.5 lbs
Fork extensions attached each (l/w/d)	64/5/8 cm; 2 kg	25/2/3 in; 4.5 lbs	64/5/8 cm; 2 kg	25/2/3 in; 4.5 lbs
Weight - adjustable forks	24 kg	52.5 lbs	24 kg	52.5 lbs
Outrigger footprint	1.87 x 2.02 m	73.5 x 79.5 in	1.87 x 2.02 m	73.5 x 79.5 in
Casters	standard casters		standard casters	

Power

Average cranks: standard winch	27.8 cranks/m	8.5 cranks/ft	27.8 cranks/m	8.5 cranks/ft
--------------------------------	---------------	---------------	---------------	---------------

Weight

	230 kg	507 lbs	252 kg	555 lbs
--	--------	---------	--------	---------

Standards Compliance

EU Directive: 2006/42/EC (Machinery)

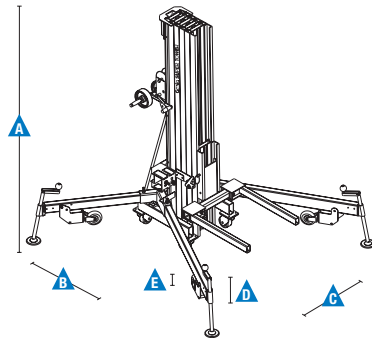

Features

Standard Features	Easily Configured To Meet Your Needs	Options & Accessories
-------------------	--------------------------------------	-----------------------

Measurements

ST™-20

- 6.46 m (21 ft 2.5 in) maximum lifting height
- Up to 363 kg (800 lbs) load capacity

ST-25

- 7.94 m (26 ft 0.5 in) maximum lifting height
- Up to 295 kg (650 lbs) load capacity

Productivity

- Use as a single unit, or two or more can be used together to support trusses
- Flat black anodized finish is nearly invisible to audience
- Portable and compact design
- Lightweight, durable aluminum construction
- Easy set-up with no tools required
- Durable steel forks
- Hand winch locks in place when handle is released
- Easy to transport—no bulky base
- Hold-down mechanism secures carriage during transport

Power

- One-speed manual winch
- Reversible winch handle for easy storage

Productivity & Fork Options

- Adjustable width forks (standard)
- Load platform
- Fork extensions

Power Options

- One-speed manual winch (standard)
- Two-speed manual winch ⁽¹⁾

Base

- Standard base

Casters

- Standard casters

Productivity

- Load platform
- Fork extensions

Power

- Two speed manual winch ⁽¹⁾



⁽¹⁾ Available aftermarket only

Europe, Middle East, Africa and Russia Region

United Kingdom and Europe, T: +44 800 988 3799 (toll free) or +31 165 519 349

Middle East, Southern Africa, Russia and Turkey, T: +971 4 399 0381

Visit www.genielift.com/en-gb/about-genie/locations to view our global locations list

Worldwide Manufacturing And Distribution

Australia · Brazil · Caribbean · Central America · China · France · Germany · Italy · Japan · Korea · Mexico · Russia · Southeast Asia · Spain · Sweden · United Arab Emirates · United Kingdom · United States

Product specifications and prices are subject to change without notice or obligation. The photographs and/or drawings in this document are for illustrative purposes only. Refer to the appropriate Operator's Manual for instructions on the proper use of this equipment. Failure to follow the appropriate Operator's Manual when using our equipment or to otherwise act irresponsibly may result in serious injury or death. The only warranty applicable to our equipment is the standard written warranty applicable to the particular product and sale and we make no other warranty, express or implied. Products and services listed may be trademarks, service marks or trade names of Terex Corporation and/or their subsidiaries in the USA and many other countries. Genie is a registered trademark of Terex South Dakota, Inc. © 2020 Terex Corporation.

